

Development of Eco-Friendly Composites: Lamination Configuration and Addition of Waste Tire Rubber Particles on the Mechanical Performance of Polyester-Fiberglass Composite Plates

A.S.Abdel-Wanees, T.S. Mahmoud, I.M.Ibrahim and Ahmed O.Mosleh

Mechanical Engineering Department, Faculty of Engineering Shoubra, Benha University, Benha, Egypt

E-mail: ahmed.abdallah18@feng.bu.edu.eg

Abstract

The ever-growing problem of waste tire disposal necessitates the exploration of sustainable solutions. This research investigates the development of eco-friendly composites by incorporating recycled tire rubber particles into polyester-fiberglass laminates. The research focuses on the influence of two key factors: lamination configuration and the addition of waste tire rubber particles, on the mechanical performance of the composite plates, by correlating the lamination configuration, rubber particle content, microstructure, and resulting mechanical properties, the research aims to establish a comprehensive understanding of how these factors influence the performance of the eco-friendly composites. This knowledge will be valuable for optimizing the design and manufacturing processes of these composites for various applications where sustainability and tailored mechanical properties are critical. The results revealed that the inclusion of reinforcements significantly improves the material's performance. Fiberglass enhances its strength, while rubber particles, especially in specific configurations, improve its elasticity and strain resistance – this is confirmed by toughness and fracture strain tests. Notably, impact resistance also increases, making it suitable for high-impact applications

KEYWORDS: Polymer Composites, Polyester-Fiberglass Composites, Mechanical Properties, Recycling, Waste Tire Rubber Particles.

1. INTRODUCTION

Unsaturated polyester resin (UPR) is low viscosity a thermoset polymer that is commonly used in a variety of applications, such as car body parts and yachts. UPR is a thermoset because it is a cross-linked polymer, meaning that the polymer chains are linked together in a three-dimensional network. This makes UPR a rigid material that is not easily melted or dissolved [1]. Overall, UPR is a versatile material that can be used in a variety of applications. However, its brittleness can limit its use in some applications.[2]

Fiber-reinforced polymer (GFRP) composites are finding widespread use in various engineering applications due to their advantageous combination of properties. They offer tailorable mechanical behavior influenced by factors like fiber type, fiber orientation, and matrix properties. By strategically aligning and composing the glass fibers, GFRP composites can achieve desired characteristics and functionalities, often exceeding the performance of traditional materials. For instance, they can possess stiffness comparable to steel while being lighter and offer exceptional strength compared to other polymer composites at a competitive cost. This combination of benefits makes GFRPs a highly attractive material for engineers.[3]

The growing problem of waste tires presents a critical opportunity for scientists and industry to collaborate on sustainable solutions that address environmental, social, and economic concerns [4]. Using recycled rubber particles as a filler in composites can improve their impact resistance and reduce their density, which can be advantageous for certain applications [5]. Automotive bumpers, Marine components, building materials, and Impact-

resistant flooring are some examples of how polyester-fiber composites filled with waste tire rubber particles can be used in different applications, depending on the desired mechanical behavior [6]. The laminate composite with the filler particles can be added to the composite in different sizes and percentages to achieve different results in composite properties.[7]

EL-Wazery et al. [8] demonstrate that glass fiber-reinforced polyester composites with different fiber contents can be successfully fabricated using a simple hand lay-up technique. The tensile strength, flexural strength, and impact energy of the composites increased with increasing glass fiber content, from 28 MPa to 79 MPa, 45 MPa to 119 MPa, and 3.5 Joules to 6.50 Joules, respectively. The hardness value also increased from 32 BHN to 47 BHN. These results show that the mechanical properties of polyester resin can be significantly improved by the addition of glass fiber reinforcement. F. Findik et al.[9] concluded that the improvement in the mechanical properties of the composite as the hardness, tensile strength, breaking work, Charpy strength, and bending strength all increase with increasing glass fiber content, This is because the glass fibers act as load-bearing reinforcements, which can help to prevent the polymer matrix from deforming or breaking, and the most pronounced for glass fiber contents between 9 and 33%. This is because, at these levels, the glass fibers can form a strong bond with the polyester matrix, while still allowing for some flexibility. Tong Yuanjian and D.H. Isaac [10], studied the fatigue behavior of glass fiber-reinforced polyester resin composites and concluded that Glass fiber-reinforced composites with low energy impact result

in matrix degradation, which modifies the tensile characteristics of matrix-dominated ± 45 lay-ups but not fiber-dominated 0/90 geometries. Increased impact energy causes fiber breakage, which lowers the 0/90 lay-ups tensile performance. The impact damage has a noteworthy impact on the fatigue lifespan that follows, and research indicates a strong correlation between the fatigue performance and the post-impact residual tensile strength. All the data are around a single S-N curve after normalizing the fatigue stress level to residual strength.

Besides the added characteristics to the composite by the waste tire rubber to the developed composite, it's also a sustainable design approach hoping to the solid waste management of waste tire as it does not derogate [11]. Due to the environmental and economic challenges posed by waste tires, there is a concerted effort to find profitable and environmentally friendly ways to recover and reuse [12].

Abuelenien et al. [13]. found that the addition of 50 vol.% of waste tire rubber particles to polyester composites increased the impact strength by 23%. yield strength and strain up to yield increased by 10% and 63%, respectively, when 10 vol.% of waste tire rubber particles were added. However, the ultimate tensile strength decreased by increasing waste tire rubber particle volume. Mosaad et al [14]. Investigated the drilling and delamination parameters of polyester matrix composite reinforced by fiberglass and rubber particles and found that when the feed rate is increased while the cutting speed is kept constant, the delamination factor will increase.

Tantayanon et al. [15]. Investigated the impact strength of a PP/waste tire rubber blend with three different particle sizes: 420 μm , 1.2 mm, and 2.4 mm. They found that the smallest particle size, 420 μm , resulted in a significant increase in impact strength (20%), while the other two larger particle sizes showed only a minor improvement. Ismail et al [16]. have shown that particle sizes below 500 μm have better mechanical properties than larger particle sizes as reinforcement in the polymer composite.

Rubber particles were found to boost the durability of vinyl ester resins, making them more resistant to fractures, by Dreerman et al.[17] However, to attain this improvement, some flexibility and resistance to bending had to be given up. H. Ismail et al.[16], prepared Polypropylene/Waste Tire Dust blends using three different sizes of WTD in a Haake Rheomix Polydrive R 600/610 at 180°C and 50 rpm for 9 minutes. Results showed that blends with the finest WTD size had higher torque, tensile strength, Young's modulus, and elongation at break compared to blends with coarse WTD. The swelling index of blends with fine WTD

was slightly lower in both oil and toluene. Scanning electron micrographs revealed better adhesion in blends with fine WTD compared to those with coarse WTD.

Safaa et al [18], found that a specific mixture of waste PVC and tires combined with polyester and hardener can create a composite material with high tensile strength. Thermal conductivity values increase with mixing conditions but can be reduced by using higher percentages of waste tires and polyester or waste PVC and polyester. Mixing waste PVC and tires with polyester improves the hardness and flexibility of the resulting material. Recommendations include a 4.5% PVC, 4.5% tire, and 91% polyester and hardener mixture for improved tensile strength, and an 8.3% PVC, 8.3% tire, and 83.4% polyester and hardener mixture for high hardness.

In this context, this study aims to investigate the effect of incorporation of waste tire rubber particles with fiberglass as hybrid reinforcement for polyester matrix composite, besides optimizing the best laminate configuration according to the mechanical performance.

2. Methodology

2.1 Material

SUNPOL, a Turkish company, supplied unsaturated polyester resin with a density of 1.23 g/cm³. HOPPEC, an Egyptian company, supplied recycled rubber particles with a mean density of 0.4 g/cm³. The particles were sized 20 mesh (0.841 mm). Jushi Chinese-Egyptian Company supplied fiberglass with product number E01, with a density 1.4 g/cm³, and a roll width of 1524 mm.

2.2 Composite preparation

The composite laminate was prepared using hand layup, the first specimen was made from unsaturated polyester resin (UPR). The first composite (COMP 1) was made from unsaturated polyester resin and reinforced with 5 vol.% fiberglass, while (COMP 2) consisted of polyester resin as layer 1, layer 2 consisted of rubber particles mixed with polyester, and finally, Layer 3 was fiberglass material with another polyester resin, the third composite (COMP 3) differs from the first one in the point of novelty as layer 3 replaced layer 2 in the arrangement. The final laminate configuration in (COMP 4) first layer of polyester and rubber particles, the second layer consists of unsaturated polyester resin and the final layer consists of polyester and fiberglass. Table 1 shows the lamination setting and constituents. The hardener is added to the matrix resin as recommended by the supplier and the mixture of the matrix resin and the additive are put in a vacuum chamber at 0.8 bar for degassing, then it poured into a silicon mold with the required sample size.

Table (1) Constituents of composites laminates in volume %

| Layers | Comp 1 | Comp 2 | Comp 3 | Comp 4 |
|----------------|---|--|---|--|
| Layer 1 | Unsaturated polyester resin is about 32% | Unsaturated polyester resin is 25 % | Unsaturated polyester resin is 25 % | Waste tire rubber particles of 20 % mixed with another unsaturated polyester resin is 25 % |
| Layer 2 | Like layer 1 also, Unsaturated polyester resin is about 32% | Waste tire rubber particles of 20 % mixed with another unsaturated polyester of about 25 % | 5% Fiberglass material with another polyester resin is 25 % | Unsaturated polyester resin is 25 % |
| Layer 3 | 5% Fiberglass material with another 32% polyester resin | 5% Fiberglass material with another polyester resin is 25 % | Waste tire rubber particles of 20 % mixed with another unsaturated polyester of about 25 % of | 5% Fiberglass material with another polyester resin is 25 %. |

The composite was prepared according to the following steps [19]:

Step 1: A mold for the composite specimens was created using silicon rubber, following the desired dimensions as shown in figure 1:

- **Tensile Mold:** This mold have dimensions of $300 \times 170 \times 30$ mm ($a \times b \times c$), to give samples with required dimension $(250 \times 25 \times 3)$ mm as mentioned in figure 3.
- **Impact Mold:** This mold will be smaller, measuring $180 \times 120 \times 30$ mm ($a \times b \times c$), to give samples with required dimension $(127 \times 13 \times 7)$ mm as mentioned in figure 4.

Step 2: For resin Preparation the required amount of polyester resin was measured based on the target volume fraction. To eliminate trapped air, the resin was degassed in a vacuum chamber.

Step 3: The hardener, following the manufacturer's recommendations, was mixed with the degassed resin. The mixture underwent further degassing for in the vacuum chamber.

Step 4: The degassed resin mixture was poured into the prepared mold and allowed to solidify completely.

Step 5: For hybrid reinforced specimens, rubber particles were incorporated into the resin-hardener mixture created in step 3. This mixture was then poured into the mold and cured as described in step 4.

Step 6: For fiber-reinforcing, fiberglass mat, cut to the required dimensions, was placed in the mold. The resin-hardener mixing and degassing steps (step 3) were repeated to create a layer of resin over the fiberglass mat.

Step 7: All molded specimens were cured in the mold for approximately two hours.

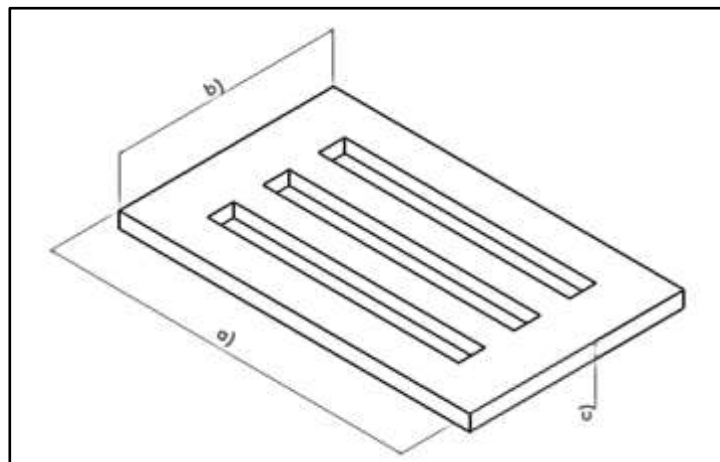
**Fig. (1)** Silicon mold dimension illustration.

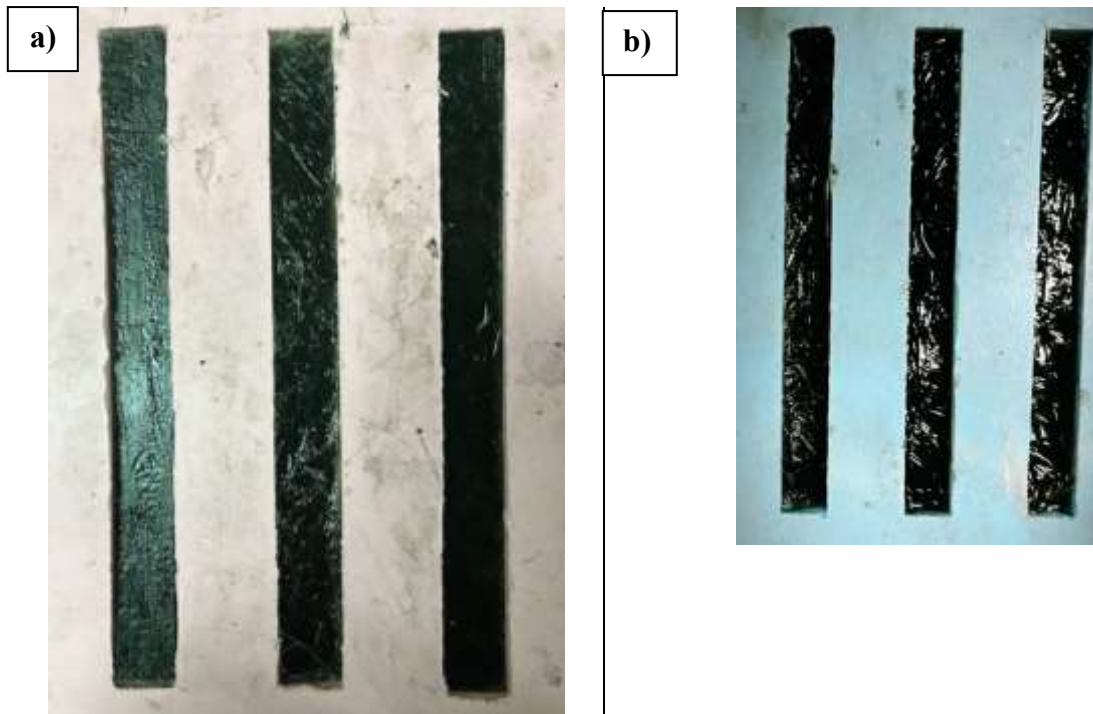

Fig. (2) Samples within the silicon mold a) tensile samples b) impact samples.

2.3 Physical properties characterization

The practical method for estimating the densities of different composite configurations is to weigh the specimen, which can be done using a digital scale with an accuracy of 0.01 g, measure its dimensions, and then divide the mass by the volume to find the density. Knowing the densities and volume percent of each component, the densities of composites are also computed theoretically using the rule of mixture.

$$\rho(\text{practical}) = \frac{\text{Mass}}{\text{Volume}}$$

$$\rho(\text{theoretical}) = \sum(\text{Volume \%} \times \rho(\text{of each component}))$$

2.4 Microstructural and morphological analysis

Samples from the prepared composites were sawn then ground and polished to be prepared for

the microscopic examination by optical microscope (OM) according to the standard metallography methods. The fracture surface of the tensile specimen was examined using a scanning electronic microscope (SEM).

2.5 Mechanical properties characterization

Zwick universal tensile testing machine, Germany with load cell 10 KN and at extensometer speed 2 mm/min is employed according to ASTM D 3039 / D 3039M to perform the tension test with specimen dimensions shown in Figure 3.[20]. The impact test is done according to ASTM D 6110-04. The test was performed at room temperature using a JB-300B impact tester from Jinan Shijin Group Corporation. Figure 4 shows the impact test's specimen dimensions according to the mentioned standard.[21]

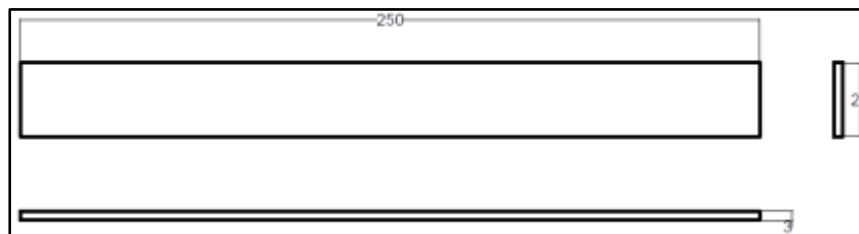

Fig. (3) Tensile sample dimension in mm

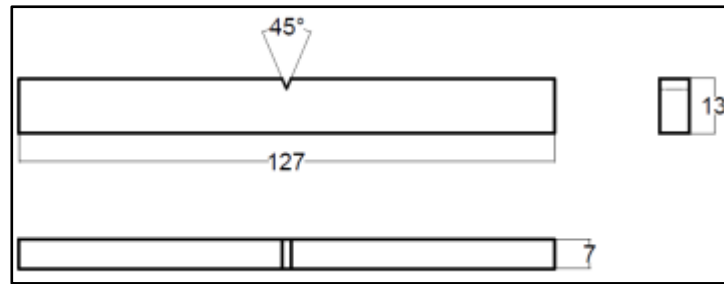

Fig. (4) Impact sample dimension in mm.

3. Results and discussions

3.1 Physical properties

For specimens with the same volume, practical densities are computed. Afterwards, the mean density is measured.

Theoretical densities are obtained for Comp 1, 95 vol. % unsaturated polyester resin, and 5 vol. % fiberglass, theoretical densities are obtained. Likewise, Comp (3, 4, 5) contains the volume fraction % of material but with different laminate arrangements, 75% polyester, 20% rubber particles, and 5% fiberglass. The density of the composite is 1.0725 g/cm³.

Figure 5 shows the comparison between the practical and theoretical densities of composites indicating that the preparation procedure is effective, as the values closely match. This suggests that there are minimal voids or defects present in the material. The addition of rubber particles may slightly increase variation, but it remains within acceptable limits.

The results demonstrate that using rubber and polyester fiberglass composite instead of

unsaturated polyester resin results in a 17.2% decrease in density. Additionally, an 18.64% reduction in density is achieved when using polyester-fiberglass composite instead of unsaturated polyester resin.

3.2 Microstructure analysis

Examining the composite's microstructure reveals valuable information about the reinforcement mechanisms. By closely observing how the tire rubber particles are distributed within the polyester resin (matrix) and how they interact with the fiberglass fibers, researchers can gain crucial insights into the particle's role in strengthening the composite. This knowledge is essential for tailoring the material's properties to achieve optimal performance in its intended application.[22]

Furthermore, microscopic analysis can unveil potential weaknesses within the composite. Defects like voids (air gaps), cracks, or weak interfacial bonding between the components (fiberglass, polyester, and rubber particles) can be identified as in the following figure.[23]

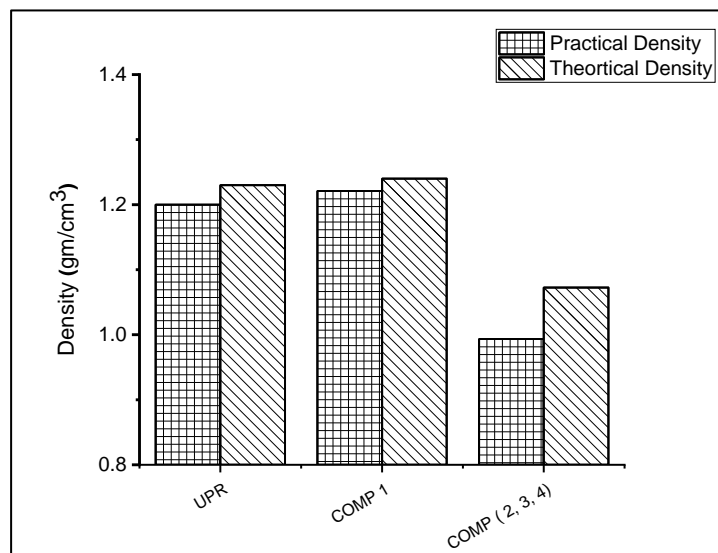

Fig. (5) Practical vs theoretical density.

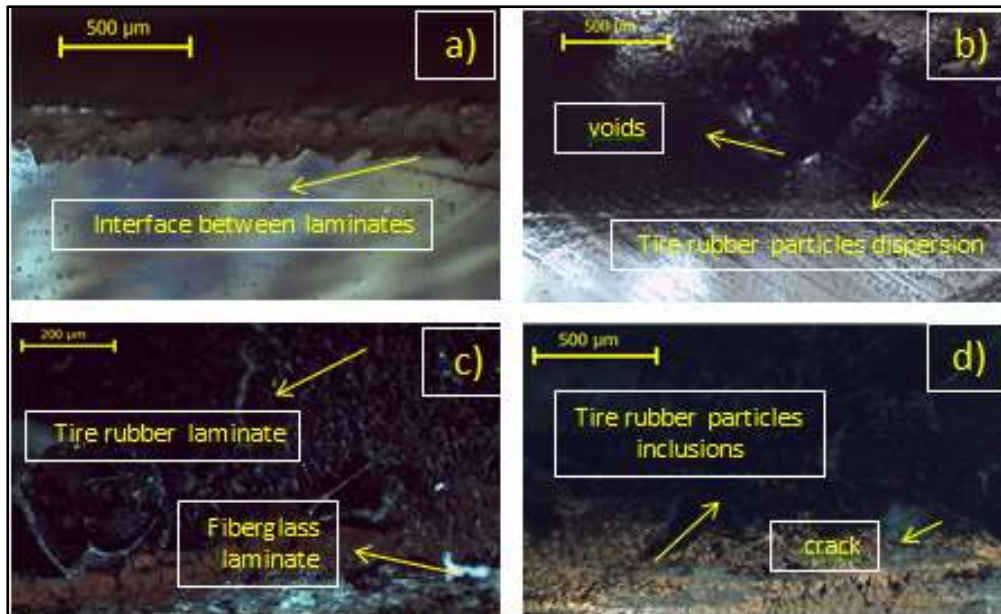

Fig. (6) Microstructure of the developed composites (a) COMP 1 (b) COMP 2 (c) COMP 3 (d) COMP 4

3.3 Mechanical properties

The stress-strain curves are essential for understanding how the material deforms under tension. This analysis will determine the maximum tensile strength each composite sample can withstand. Generally, rubber has lower inherent strength than fiberglass or polyester, especially in tension. This inclusion can weaken the overall composite structure. Rubber particles might disrupt the transfer of stress between the strong fiberglass fibers and the polyester matrix, hindering load distribution. Excessive stress can lead to premature failure of the composite [6], [24].

Stress-strain curve of the composites is shown in figure 7, the addition of fiberglass has a noticed effect on withstand of material [25], while the addition of rubber particles enhances the strain characteristics of the composite due to the natural behavior of the rubber.[26]

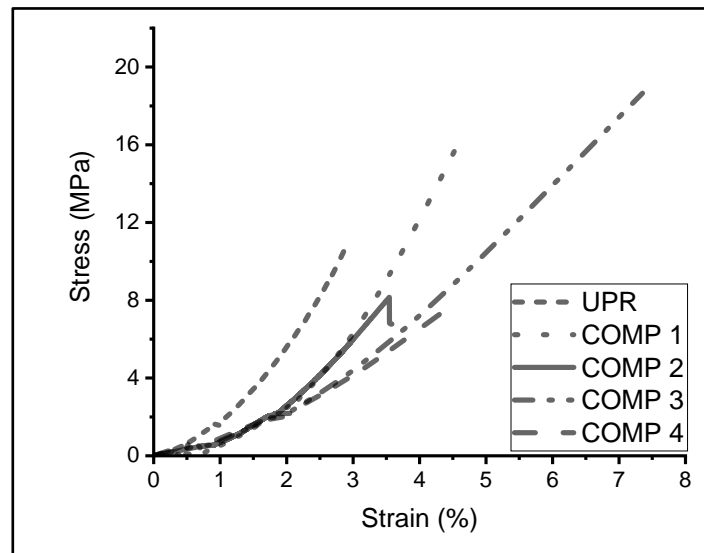

Fig. (7) Stress-strain curve of the composites

Figure 8 shows the effect of the composite density on the ultimate tensile strength as the one of the improvements proven figure 5, the laminate configuration in COMP 3 as the fiberglass is the core laminate shows the better specific ultimate tensile strength due to the better tensile load withstanding and distribution of woven fiberglass [27].

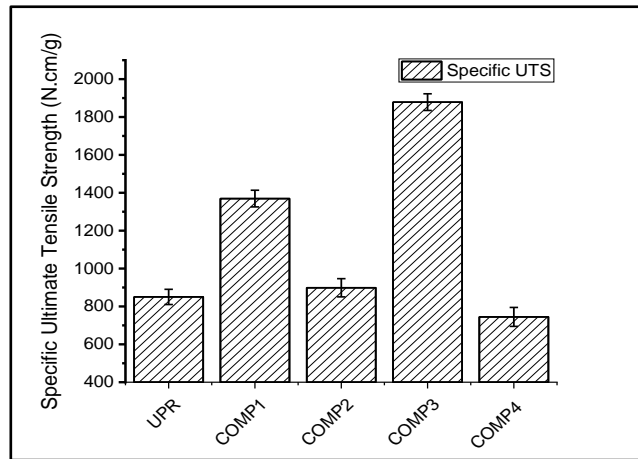

Fig. (8) Specific ultimate tensile strength of the composites.

The amount of strain energy stored per unit volume of the material up to fracture divided by the density of composite which defined the specific modulus of toughness [28], figure 9 expresses the variation of this property in the different investigated where there findings agrees with the strain results in figure 10, Even though the hybrid reinforced COMP 3 has an absolute advantage over the polyester fiber composite when the weight is essential factor as a result of the addition of tire rubber particles.

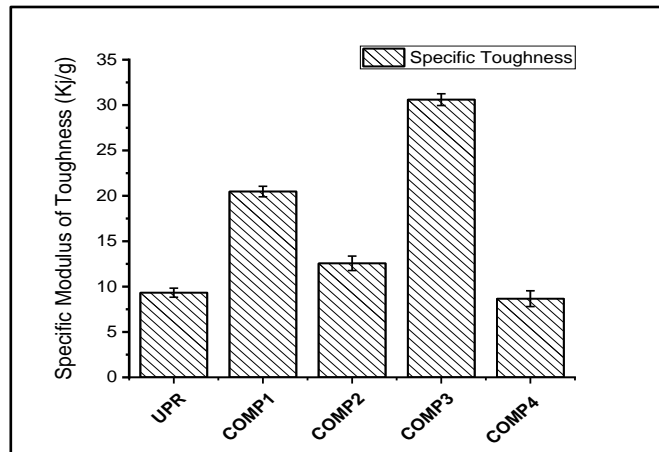

Fig. (9) Specific toughness of the composites

The strain of the composites till fracture has increased with adding of fiberglass by 60.5% and then varied according to the configuration of the laminate arrangement; however COMP 3 showed also the better strain characteristics as a hybrid reinforced composite than unsaturated polyester – fiberglass composite by 57.2%, which revealed in figure 10.

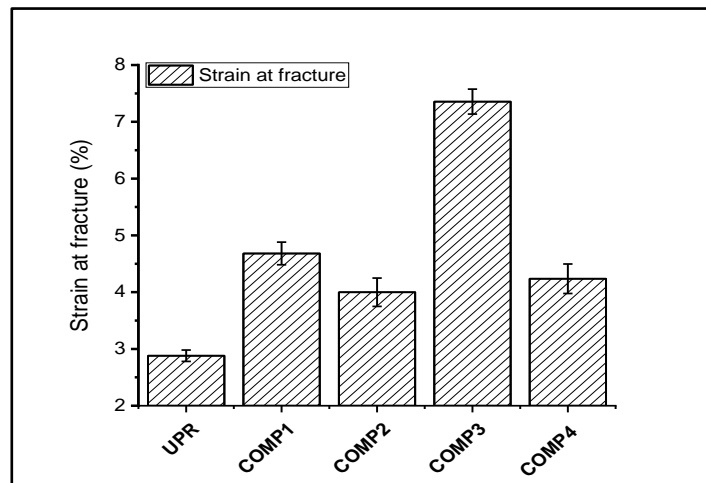

Fig. (10) Strain characteristics of the composites

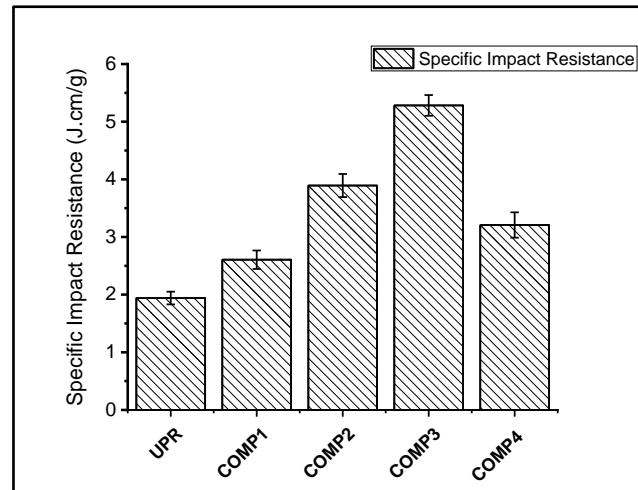

Fig. (11) Specific impact resistance of the composites.

3.4 Specific impact resistance

The rubber is known for its elasticity and the dissipation of energy behavior where it can deform locally to reduce the stress transferred to the composite, however the weak interface due the poor adhesion between polyester and rubber particles may create weak spots in the laminates beside the possibility of particles accumulation leads to premature failure and crack initiation [29].

The specific impact resistance of unsaturated polyester resin and the composites material shown in figure 11, where the specific impact resistance increased by adding fiberglass reinforced laminate by 34% and reach the maximum when adding rubber particles in laminate configuration of COMP 3 by 64% improvement, then it decreased when the core laminate of composite became polyester resin in COMP 4 due its brittleness and less stiff behavior [30].

3.5 SEM and fracture analysis

Limited tensile strength of unreinforced polyester translates to a predicted brittle fracture surface. This could manifest as a relatively smooth plane with minimal plastic deformation, indicating minimal stretching prior to failure shown in figure 12 (a).

Incorporating fiberglass fibers into the polyester composite is expected to the fracture surface, making it rougher and more uneven compared to pure polyester as shown in figure 12 (b). This can be attributed to mechanisms like fiber pull-out. Under tensile stress, these fibers may

partially detach from the surrounding polyester matrix, leaving behind distinct indentations or holes on the fracture surface. Additionally, the presence of fibers can introduce a degree of plastic deformation before complete fracture. This suggests a slightly more ductile behavior compared to pure polyester, where the material fractures with minimal plastic stretching [31]

The addition of rubber particles to the composite material significantly affects its fracture behavior, but this influence is complex and depends on the specific rubber concentration and the size of the dispersed particles, with 20 mesh size composites with a 20%, the overall fracture process might not be significantly altered compared to the rubber-free P/F composite. The fracture surface might still exhibit signs of fiber pull-out and debonding, with minimal influence from the embedded rubber particles as in figure 12 (c) [32].

In figure 12 (d) the fiberglass as core laminate exhibits better adhesion as intermediate layer which also increase the composite resistance to failure and cracks due the fiberglass properties as mentioned before, while the addition of rubber showed better influence reduced the stress transferred [33].

While in figure 12 (e) the polyester as intermediate shows more brittle behavior with more significant spread crack which resulted in faster separation of the laminates with the presence of fiberglass pullout [34].

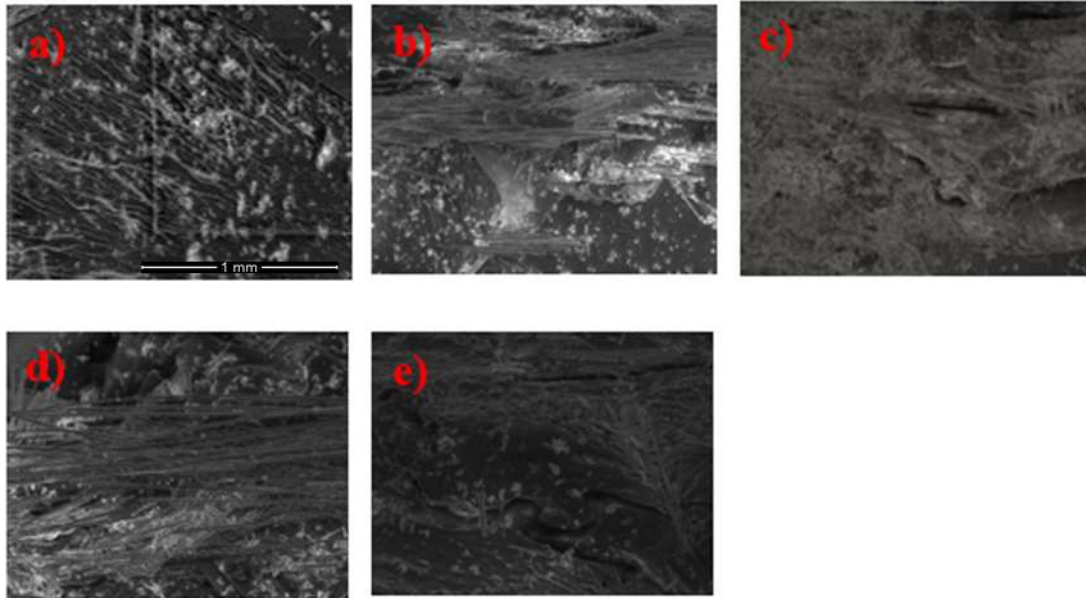

Fig. (12) Fracture surface 160X (a) polyester resin (b) COMP 1 (c) COMP 2 (d) COMP 3 (e) COMP 4

4. Conclusion

The findings demonstrate the following:

- The effectiveness of the preparation procedure, with minimal voids or defects present in the material as evidenced by the close correspondence between theoretical and practical densities. While the addition of rubber particles may introduce slight variations, these remain within acceptable limits.
- The addition of these reinforcements demonstrably improves the material's performance. Fiberglass strengthens the material's ability to withstand stress, while rubber particles enhance its strain characteristics due to their inherent elasticity. This is corroborated by the results for specific modulus of toughness and strain at fracture.
- Both COMP 3 and the fiberglass-reinforced composite (COMP 1) outperform the baseline resin. Notably, COMP3 exhibits the highest improvement in specific impact resistance (64% increase), highlighting its potential for applications requiring high impact absorption.

In conclusion, this research successfully demonstrates the effectiveness of rubber and fiberglass composites as lighter and more robust alternatives to unsaturated polyester resin. The combination of these reinforcements in COMP 3 offers a particularly attractive solution, exhibiting superior strain and impact resistance characteristics while maintaining a lower density. These findings pave the way for the development of next-generation composites with tailored properties for various engineering applications

References

- [1] M. Davallo, H. Pasdar, and M. Mohseni, "Mechanical properties of unsaturated polyester resin," *Int. J. ChemTech Res.*, vol. 2, no. 4, pp. 2113–2117, 2010.
- [2] S. M. S. Al-Mufti, A. Almontasser, and S. J. A. Rizvi, "Unsaturated Polyester Resin Filled with Cementitious Materials: A Comprehensive Study of Filler Loading Impact on Mechanical Properties, Microstructure, and Water Absorption," *ACS Omega*, vol. 8, no. 23, pp. 20389–20403, 2023, doi: 10.1021/acsomega.3c00353.
- [3] P. Morampudi, K. K. Namala, Y. K. Gajjela, M. Barath, and G. Prudhvi, "Review on glass fiber reinforced polymer composites," *Mater. Today Proc.*, vol. 43, pp. 314–319, 2020, doi: 10.1016/j.matpr.2020.11.669.
- [4] A. Fazli and D. Rodrigue, "Waste rubber recycling: A review on the evolution and properties of thermoplastic elastomers," *Materials (Basel)*, vol. 13, no. 3, 2020, doi: 10.3390/ma13030782.
- [5] M. Nuzaimah, S. M. Sapuan, R. Nadlene, and M. Jawaid, "Recycling of waste rubber as fillers: A review," *IOP Conf. Ser. Mater. Sci. Eng.*, vol. 368, no. 1, 2018, doi: 10.1088/1757-899X/368/1/012016.
- [6] B. Abu-Jdayil, A. H. I. Mourad, and A. Hussain, "Investigation on the mechanical behavior of polyester-scrap tire composites," *Constr. Build. Mater.*, vol. 127, pp. 896–903, 2016, doi: 10.1016/j.conbuildmat.2016.09.138.
- [7] G. R. Chavhan and L. N. Wankhade, "Improvement of the mechanical properties of hybrid composites prepared by fibers, fiber-metals, and nano-filler particles-A review," *Mater. Today Proc.*, vol. 27, pp. 72–82, 2020, doi: 10.1016/j.matpr.2019.08.240.
- [8] M. S. EL-Wazery, M. I. EL-Elamy, and S. H. Zoalfakar, "Mechanical properties of glass fiber

- reinforced polyester composites,” *Int. J. Appl. Sci. Eng.*, vol. 14, no. 3, pp. 121–131, 2017, doi: 10.6703/IJASE.2017.14(3).121.
- [9] F. Findik, M. Misirlioglu, and U. Soy, “The structural features of glass fibre reinforced polyester matrix composites,” *Sci. Eng. Compos. Mater.*, vol. 10, no. 4, pp. 287–295, 2002, doi: 10.1515/secm.2002.10.4.287.
- [10] T. Yuanjian and D. H. Isaac, “Combined impact and fatigue of glass fiber reinforced composites,” *Compos. Part B Eng.*, vol. 39, no. 3, pp. 505–512, 2008, doi: 10.1016/j.compositesb.2007.03.005.
- [11] F. Rodrigues André and M. Galal Aboelkheir, “Sustainable approach of applying previous treatment of tire wastes as raw material in cement composites: Review,” *Mater. Today Proc.*, vol. 58, no. April, pp. 1557–1565, 2022, doi: 10.1016/j.matpr.2022.03.456.
- [12] S. Dabic-Miletic, V. Simic, and S. Karagoz, “End-of-life tire management: a critical review,” *Environ. Sci. Pollut. Res.*, vol. 28, no. 48, pp. 68053–68070, 2021, doi: 10.1007/s11356-021-16263-6.
- [13] K. F. Abo Elenien, N. A. Azab, G. Bassioni, and M. H. Abdellatif, “The effect of tire rubber particles on the mechanical and physical properties of polyester,” *IOP Conf. Ser. Mater. Sci. Eng.*, vol. 973, no. 1, 2020, doi: 10.1088/1757-899X/973/1/012019.
- [14] M. Mosaad, T. S. Mahmoud, B. Hany Mousa, I. Mousa, and S. S. Mohamed, “Investigation On the Effect of Variation of Drilling Parameters On the Delamination Factor in Waste Tire Rubber Polyester Composite Laminates,” *Benha J. Appl. Sci.*, vol. 7, no. 4, pp. 249–252, 2022, doi: 10.21608/bjas.2022.260500.
- [15] S. Tantayanan and S. Juikham, “Enhanced toughening of poly(propylene) with reclaimed-tire rubber,” *J. Appl. Polym. Sci.*, vol. 91, no. 1, pp. 510–515, 2004, doi: 10.1002/app.13182.
- [16] H. Ismail, M. Awang, and M. A. Hazizan, “Effect of waste tire dust (WTD) size on the mechanical and morphological properties of polypropylene/waste tire dust (PP/WTD) blends,” *Polym. - Plast. Technol. Eng.*, vol. 45, no. 4, pp. 463–468, 2006, doi: 10.1080/03602550600553739.
- [17] E. Dreerman, M. Narkis, A. Siegmann, R. Joseph, H. Dodiuk, and A. T. Dibenedetto, “Mechanical Behavior and Structure of Rubber Modified Vinyl Ester Resins,” *J. Appl. Polym. Sci.*, vol. 72, no. 5, pp. 647–657, 1999, doi: 10.1002/(SICI)1097-4628(19990502)72:5<647::AID-APP5>3.0.CO;2-M.
- [18] S. A. S. Almtori, R. J. Jassim, D. C. Ali, E. H. Kadhim, and R. Al-Sabur, “Sustainable Manufacturing Process Applied to Produce Waste Polymer-Polymer Matrix Composites,” *Environ. Res. Eng. Manag.*, vol. 79, no. 1, pp. 122–132, 2023, doi: 10.5755/j01.arem.79.1.32907.
- [19] B. H. Mousa, N. A. Azab, G. Bassioni, and M. H. Abdellatif, “Assessment of the Damage Resulting from Drilling Holes in Waste Tire Rubber Polyester Composite Laminates,” *Waste and Biomass Valorization*, vol. 12, no. 7, pp. 4069–4080, 2021, doi: 10.1007/s12649-020-01291-z.
- [20] ASTM Committee D30, “D3039/D3039M: Standard Test Method for Tensile Properties of Polymer Matrix Composite Materials,” *Annu. B. ASTM Stand.*, vol. 15, pp. 1–13, 2017.
- [21] S. T. Method, “iTech Standards iTeh Standards Document Preview,” vol. 08, no. Reapproved 1989, pp. 3–4, 2000.
- [22] He Maoyong, Gu Kai, Wang Yulong, Li Zhenzhong, Shen Zhengpeng, Liu Shuai, Wei Jixiang, “Development of high-performance thermoplastic composites based on polyurethane and ground tire rubber by in-situ synthesis,” *Resour. Conserv. Recycl.*, vol. 173, p. 105713, Oct. 2021, doi: 10.1016/J.RESCONREC.2021.105713.
- [23] M. Mehdikhani, L. Gorbatikh, I. Verpoest, and S. V. Lomov, “Voids in fiber-reinforced polymer composites: A review on their formation, characteristics, and effects on mechanical performance,” *J. Compos. Mater.*, vol. 53, no. 12, pp. 1579–1669, 2019, doi: 10.1177/0021998318772152.
- [24] R. Bhat, N. Mohan, S. Sharma, A. Pratap, A. P. Keni, and D. Sodani, “Mechanical testing and microstructure characterization of glass fiber reinforced isophthalic polyester composites,” *J. Mater. Res. Technol.*, vol. 8, no. 4, pp. 3653–3661, Jul. 2019, doi: 10.1016/J.JMRT.2019.06.003.
- [25] B. J. Kim, C. Bin Oh, J. E. Lee, and M. Y. Lee, “Effects of the Simultaneous Strengthening of the Glass Fiber Surface and Polyamide-6 Matrix by Plasma Treatment and Nanoclay Addition on the Mechanical Properties of Multiscale Hybrid Composites,” *J. Compos. Sci. 2023, Vol. 7, Page 176*, vol. 7, no. 5, p. 176, Apr. 2023, doi: 10.3390/JCS7050176.
- [26] S. Huang, Q. Fu, L. Yan, and B. Kasal, “Characterization of interfacial properties between fibre and polymer matrix in composite materials – A critical review,” *J. Mater. Res. Technol.*, vol. 13, pp. 1441–1484, 2021, doi: 10.1016/j.jmrt.2021.05.076.
- [27] K. Al-Adily, M. Albdiry, and H. Ammash, “Evaluation of tensile and flexural properties of woven glass fiber/epoxy laminated composites oriented in edgewise and flatwise directions,” *Ain Shams Eng. J.*, vol. 14, no. 12, p. 102255,

- Dec. 2023, doi: 10.1016/J.ASEJ.2023.102255.
- [28] S. J. Park and M. K. Seo, "Solid-Solid Interfaces," *Interface Sci. Technol.*, vol. 18, pp. 253–331, 2011, doi: 10.1016/B978-0-12-375049-5.00004-9.
- [29] A. S.Abdel-Wanees, B. Hany Mousa, I. M.Ibrahim, and T. S.Mahmoud, "Assessment Study on the Mechanical Behavior of Polyester – Fiber Composite Laminates Filled with Waste Tire Rubber Particles," *Benha J. Appl. Sci.*, vol. 7, no. 4, pp. 21–23, 2022, doi: 10.21608/bjas.2022.251248.
- [30] A. Samir, F. H. Ashour, A. A. A. Hakim, and M. Bassyouni, "Recent advances in biodegradable polymers for sustainable applications," *npj Mater. Degrad.* 2022 61, vol. 6, no. 1, pp. 1–28, Aug. 2022, doi: 10.1038/s41529-022-00277-7.
- [31] C. Chen, C. Zhang, C. Liu, Y. Miao, S. C. Wong, and Y. Li, "Rate-dependent tensile failure behavior of short fiber reinforced PEEK," *Compos. Part B Eng.*, vol. 136, pp. 187–196, Mar. 2018, doi: 10.1016/J.COMPOSITESB.2017.10.031.
- [32] Y. Cai, Z. Liu, K. Gong, and Y. Zhang, "The effect of reinforcement particle size on the mechanical and fracture properties of glass matrix composites," *Heliyon*, vol. 9, no. 11, Nov. 2023, doi: 10.1016/J.HELIYON.2023.E21895.
- [33] Sharma Harsh, Kumar Ajay, Rana Sravendra, Sahoo Nanda Gopal, Jamil Muhammad, Kumar Rajeev, Sharma Shubham, Li Changhe, Kumar Abhinav, Eldin Sayed, Abbas Mohamed, "Critical review on advancements on the fiber-reinforced composites: Role of fiber/matrix modification on the performance of the fibrous composites," *J. Mater. Res. Technol.*, vol. 26, pp. 2975–3002, Sep. 2023, doi:10.1016/J.JMRT.2023.08.036.
- [34] E. Farmand-Ashtiani, D. Alanis, J. Cugnoni, and J. Botsis, "Delamination in cross-ply laminates: Identification of traction-separation relations and cohesive zone modeling," *Compos. Sci. Technol.*, vol. 119, pp. 85–92, Nov. 2015, doi: 10.1016/J.COMPSCITECH.2015.09.025.